

Grind nr. 1

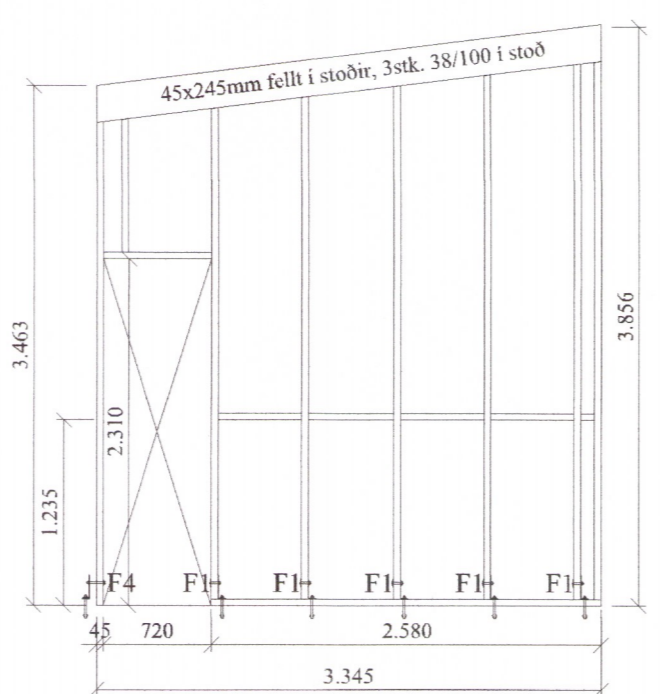

Grind nr. 2

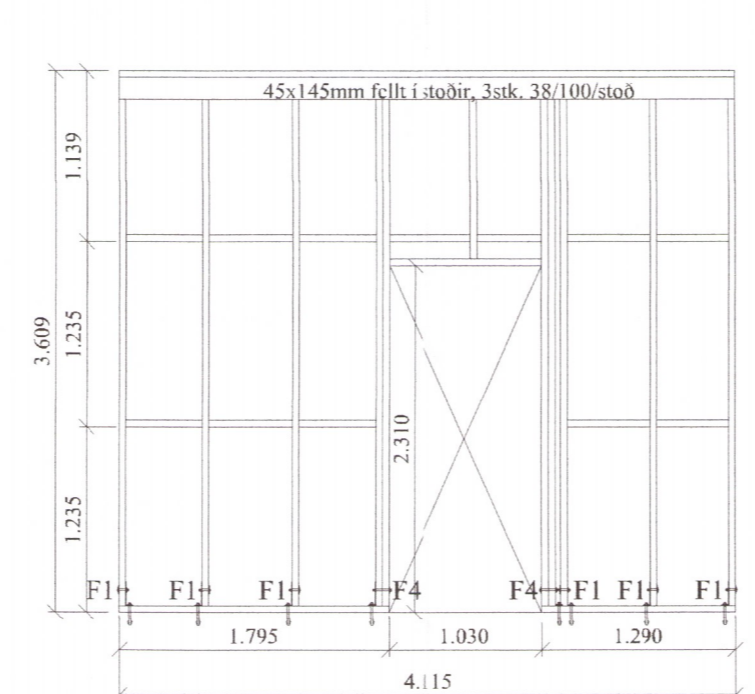

Grind nr. 3

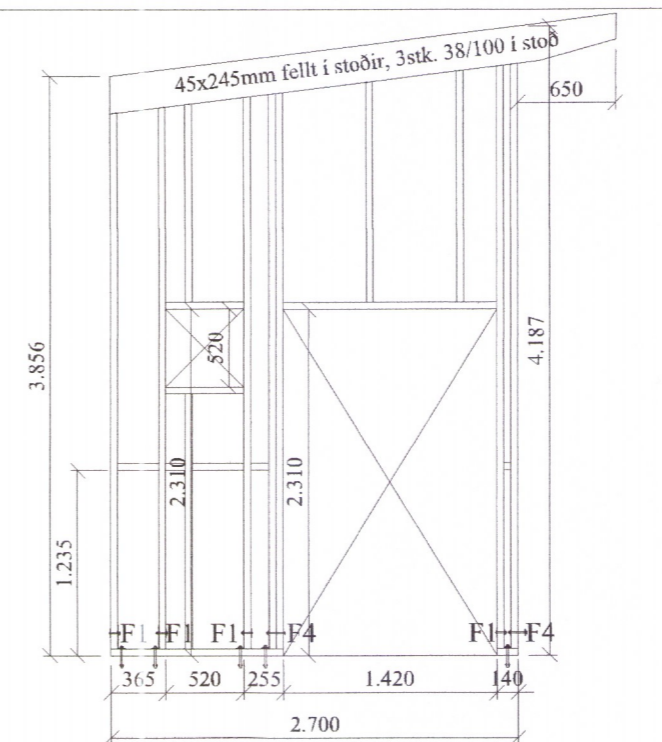

Grind nr. 4

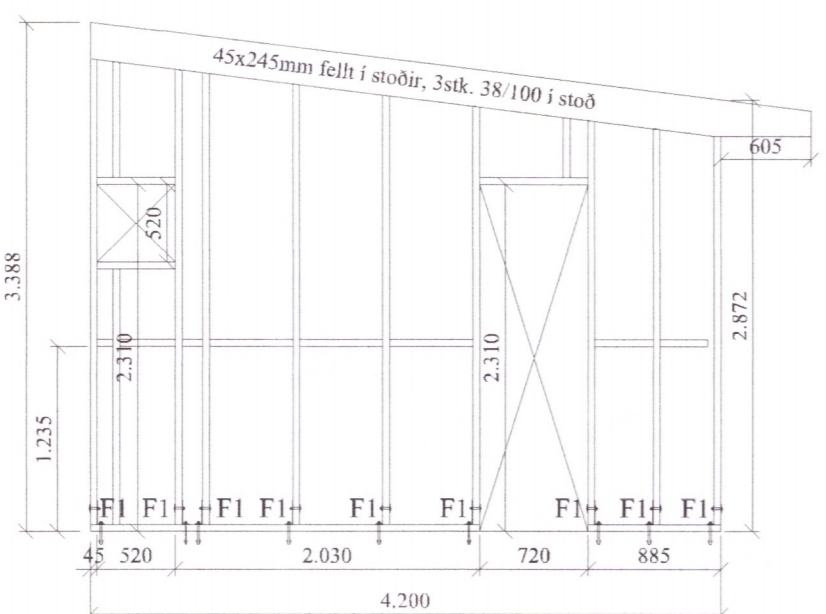

Grind nr. 5

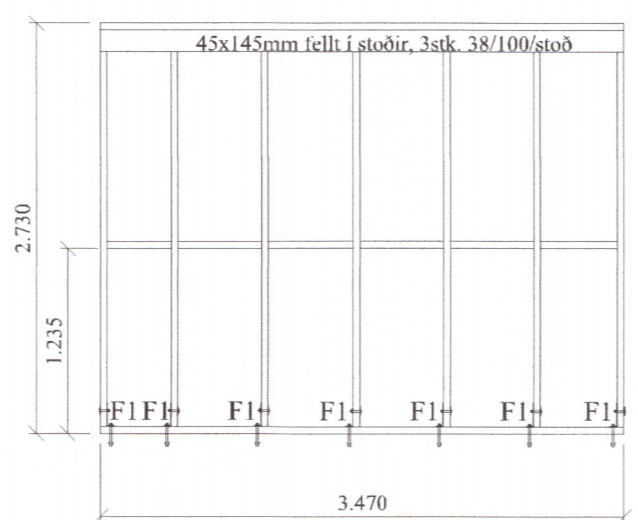

Grind nr. 6

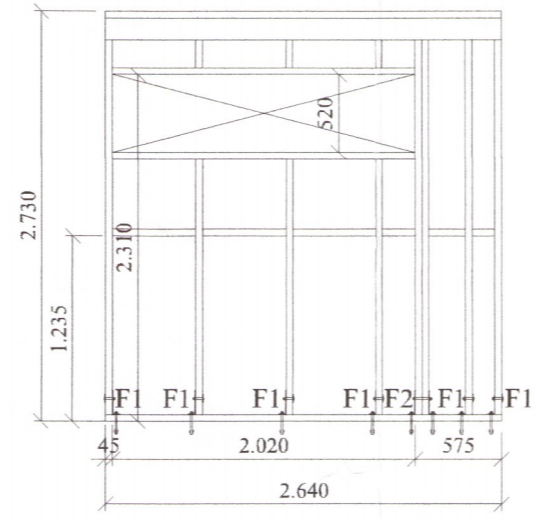

Grind nr. 7

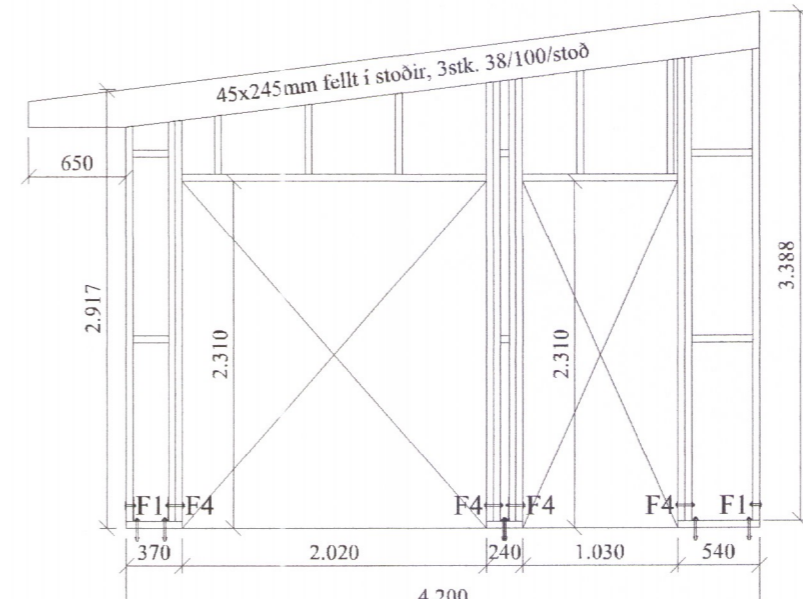

Grind nr. 8

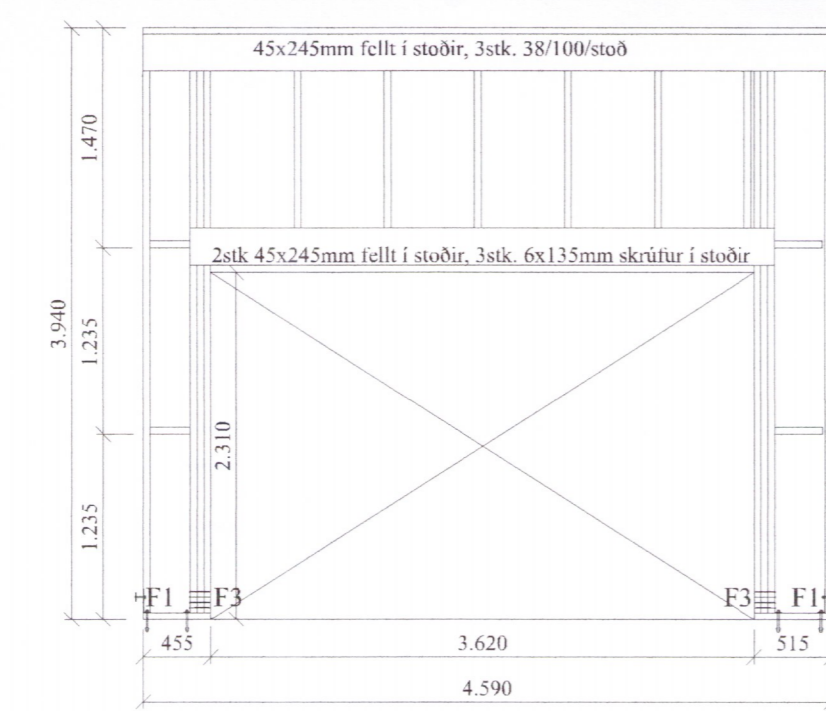

Grind nr. 9

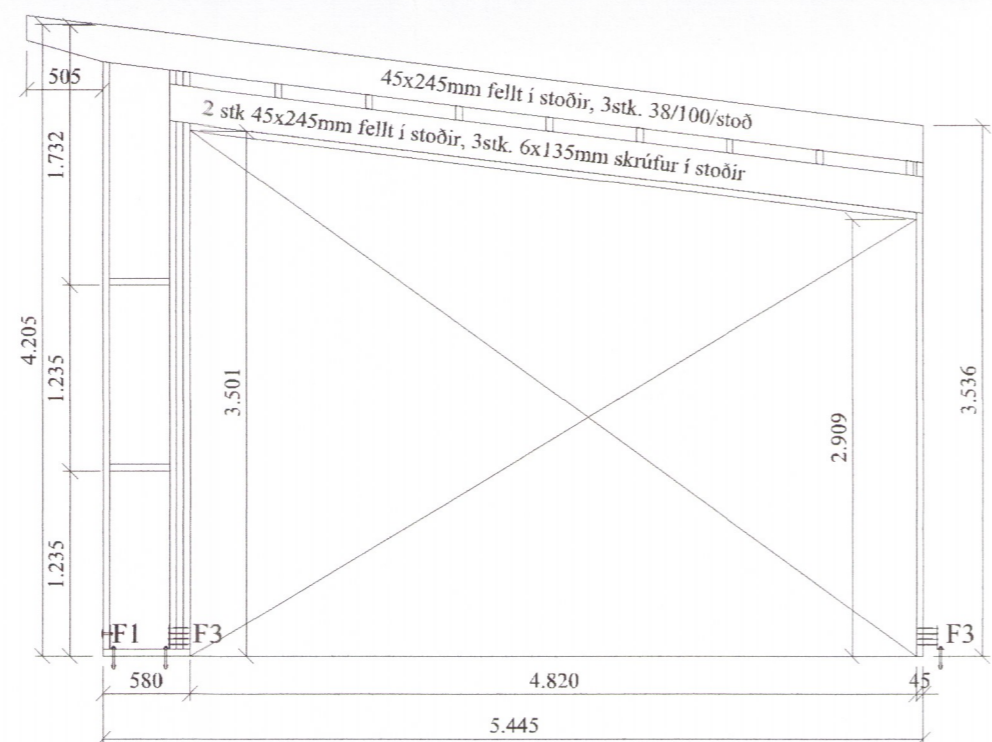

Grind nr. 10

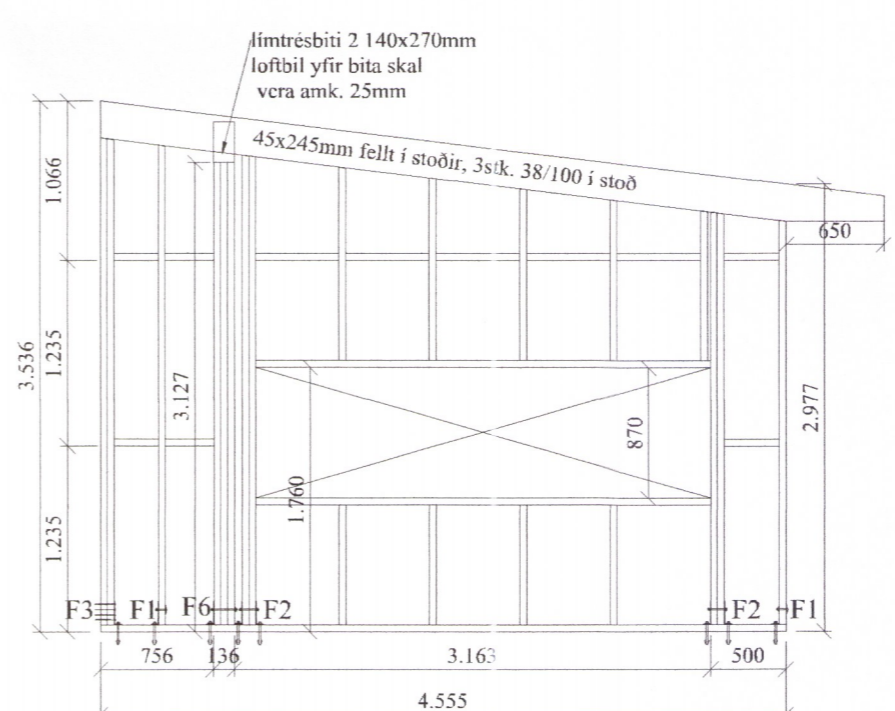

Grind nr. 11

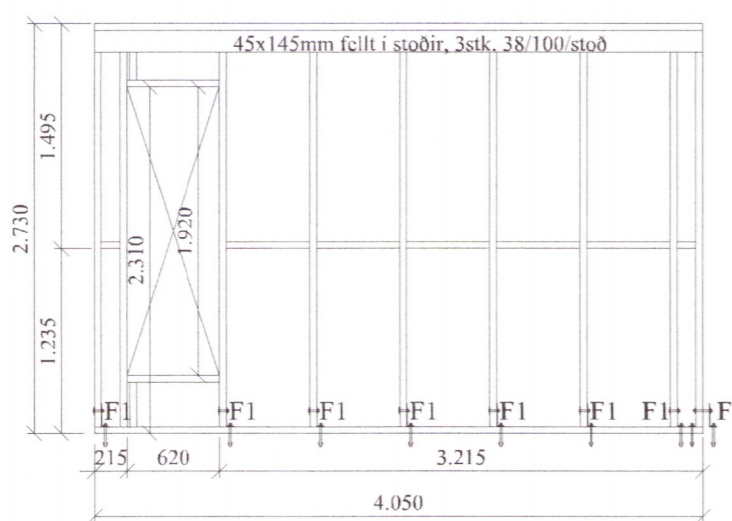

Grind nr. 12

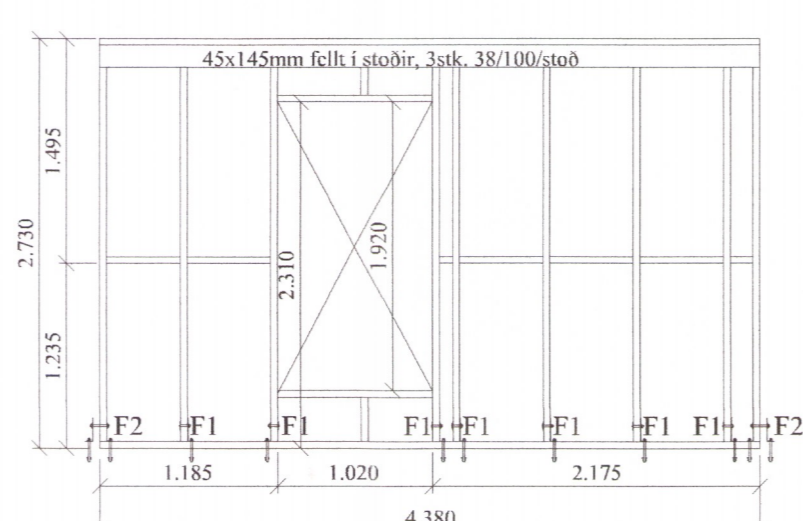

Grind nr. 13

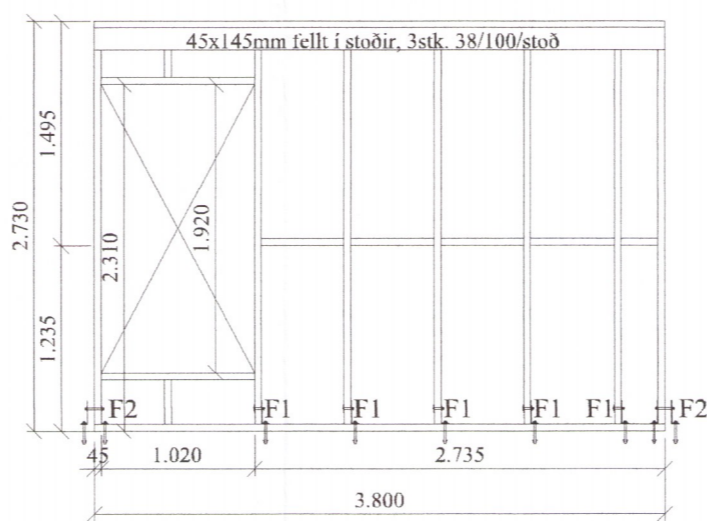

Grind nr. 14

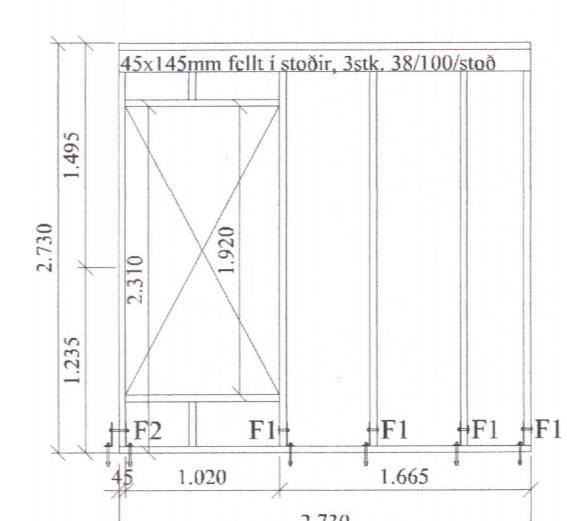

Grind nr. 15

Almennt:

Öll mál skulu staðfest skv. aðalteikningum. Ef eitthvert misræmi er skulu aðalteikningar vera ráðandi, þó ber að láta hönnuði vita af misræmi.

Skýringar - trévirki veggja

Allur viður er C24 eða betri. Allan við utanhúss skal fúaverka. Allur saumur og festingar utanhúss skulu vera heitzinkhúðaðar eða ryðfriar. Allar stoðir og lausholt eru ⁴⁵/₁₄₅ nema annað sé tekið fram. Bil á milli miðjulinu stoða skal ekki vera meira en 600 mm. Utan á grind komi 9 mm gufuopinn rakapólinn krossviður (t.d. grenikrossviður). Krossviður festist með ²⁸/₆₅ C150 í rakapólið lím. Þétting (Aerofil-púlsa eða Illmod þétting) komi undir fótstykki, einnig skal setja vindpappa undir fótstykki, sem kemur þá á milli steypu og fótstykkis.

Festingar á öllum samskeytum:

Öll horn og einingasamskeyti skal vixlskrúfa saman með 6x80mm skrifum c/c 400mm.

Festing á fótstykki

Múrboltar M12 C600 koma í gegnum fótstykki. Borddypt = 105 mm og snertidýpt bolta við steptan flöt => 80 mm.

F1 - F6 sjá sérmýndir.

1007-20

Öll mál eru í millimetrum, nema annað sé tekið fram.

Br: Breyting	Dags:	Samþ:
VERKHEITI: Hvönn 800 Selfoss	TEIKNUMÉR: 201	
VERKHLUTI: Burðarvirki Ásýnd veggja	ÚTGÁFA: A1	
Hönnuður: Leifur Örn Leifsson 150982-4139	Samþykkt: <i>[Signature]</i>	BLADSTÆRÐ: A-2
Yfirfarið af hönnunarstjóra: Bent Larsen kt. 141177-3469	Samþykkt: <i>[Signature]</i>	DAGS: 26.09.19
LARSEN HÖNNUN OG RAÐGJÖF		VERKNR: 19-34
Bent Larsen Fróðason Byggingrafæðingur B.Sc Sími 844-7699 tölvupóstur: bent@larsen.is		MKV: 1:50 / 1:10